

MCU-DM150

*Dimmer for 110-240 V AC loads up to
150 W with RX 433.92 MHz, 2 wired inputs.*

linea

NEXTA
RADIO

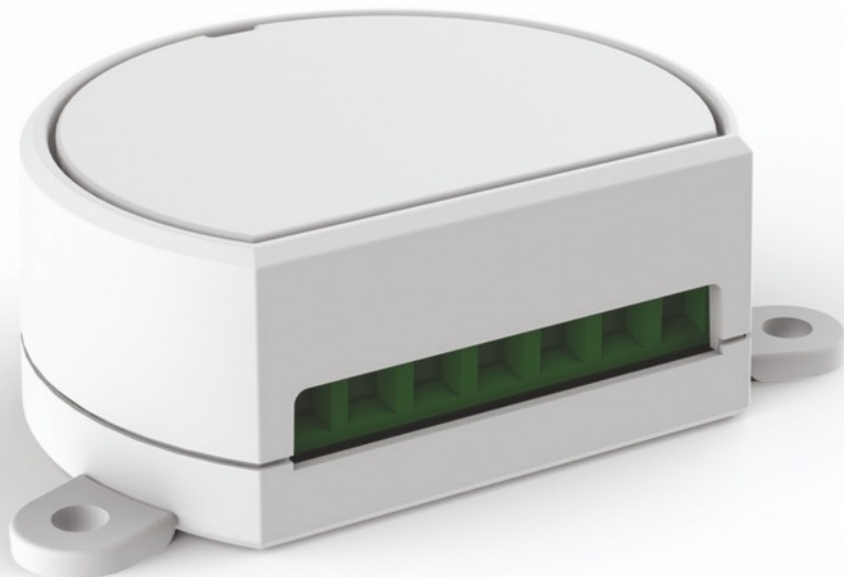

INDEX

1 - PRODUCT FEATURES

1.1 - TECHNICAL DATA

1.2 - DESCRIPTION

1.3 - CONFIGURATION DEPENDING ON TYPE OF LAMP

2 - ELECTRICAL CONNECTIONS

2.1 - THREE-WIRE CONNECTIONS

2.2 - FOUR-WIRE CONNECTIONS

3 - USE OF THE CONTROL UNIT

3.1 - USE VIA RADIO

3.2 - USE VIA WIRE

4 - CONTROL UNIT SETTINGS

4.1 - CONFIGURATION OF BUTTONS VIA WIRE

4.2 - FADE SETTING: GRADUAL SWITCH ON

4.3 - FADE SETTING: GRADUAL SWITCH OFF

4.4 - SETTING ADJUSTABLE MINIMUM BRIGHTNESS

4.5 - "SAVE" FUNCTION (BRIGHTNESS LEVEL AT SWITCH-ON)

4.6 - TWO-WIRE CONNECTIONS

5 - RADIO PROGRAMMING

6 - DELETION OF TRANSMITTERS

WARNINGS

- Installation must be carried out only by qualified technicians in compliance with the electrical and safety standards in force.
- All connections must be made with the power turned-off.
- Use suitable cables.
- Do not cut through the aerial (see picture 1.1b)
- A suitably sized disconnection device must be set up on the electric power line that supplies the product.
- Disposal of waste materials must fully respect local standards.

1 - PRODUCT FEATURES

1.1 TECHNICAL DATA

Power supply	Mains 90-260 V AC
Output	230V Max 150W, 110V max 75W
Type of load: dimmable	dimnable lamps (example: dimmable LED, halogen) resistive load, AC motors, electronic transformers dimmable with trailing or leading edge
N° programmable transmitters	100
Radio frequency	433.920mhz ISM
Protection rating	IP20
Operating temperature	-20 +55 °C
Dimensions	52x43x21 mm

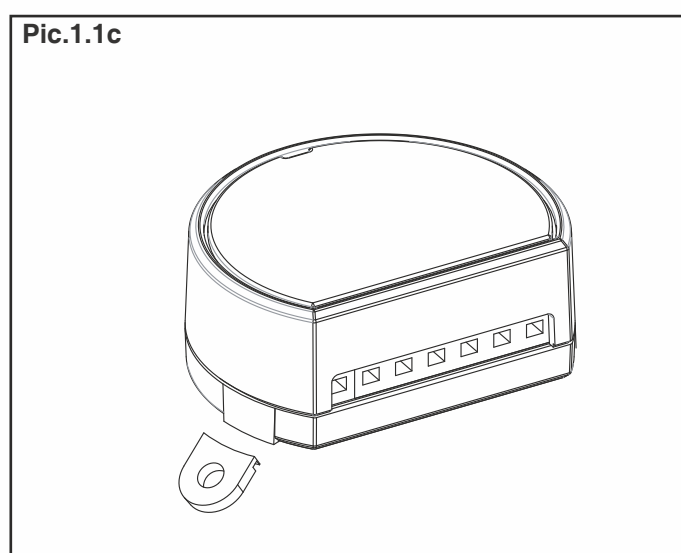
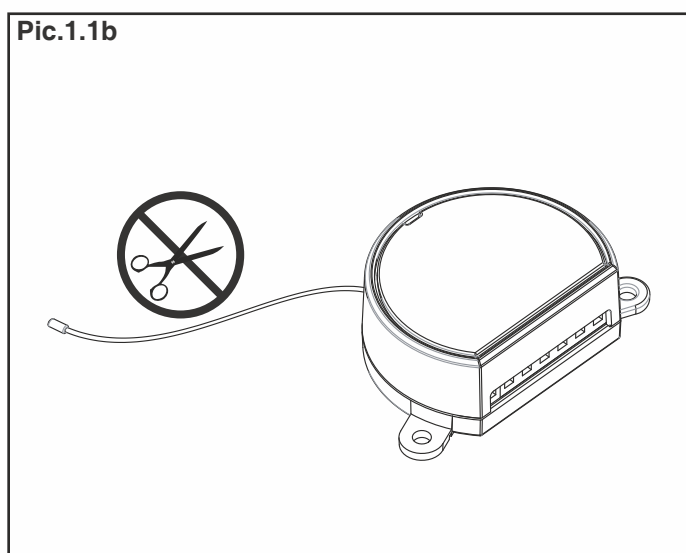
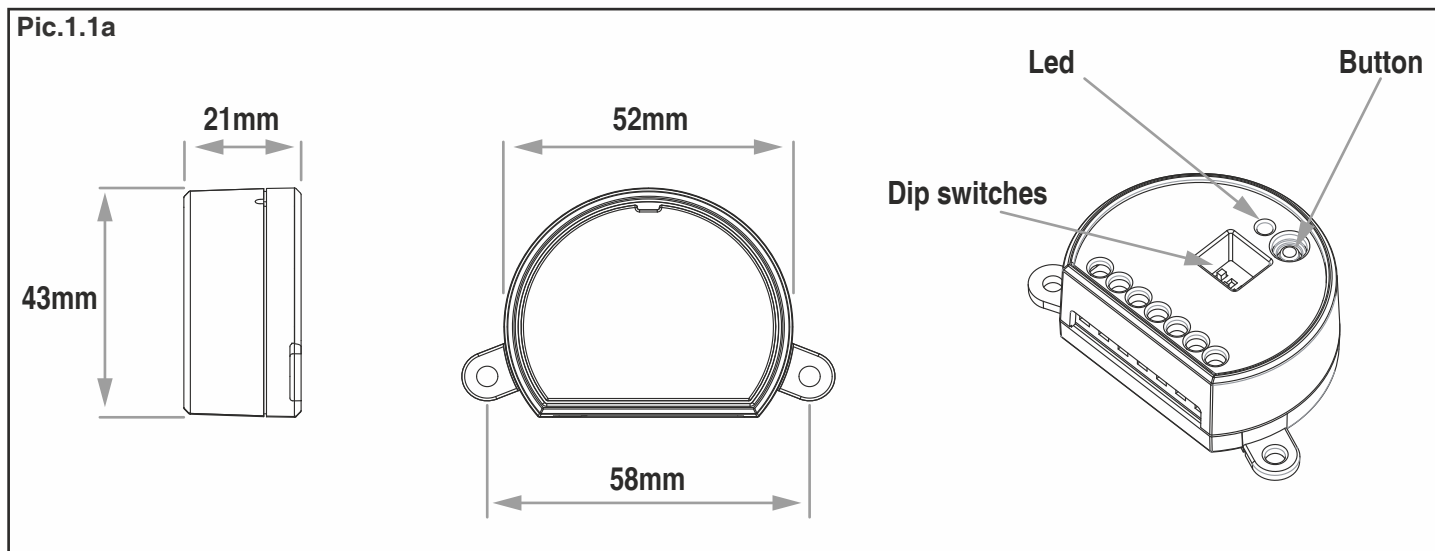

1.2 DESCRIPTION

Electronic control unit with dimmer function, for wireless and wired control of LED lights and resistive, inductive and capacitive loads (standard and electronic transformers) up to 150 W
2 wired inputs that can be set, including a specific one-hour fade function.

Wide-ranging and accurate dimmer function; fade on and off that can be set to between 0 and 10 seconds.
The ISM (industrial, scientific and medical) radio frequency band guarantees a long range, even through walls and ceilings.

Simple programming with dip-switches, reduced dimensions with breakable tabs for fixing with screws or for insertion into connection boxes 55 mm in diameter.

Pic.1.2a

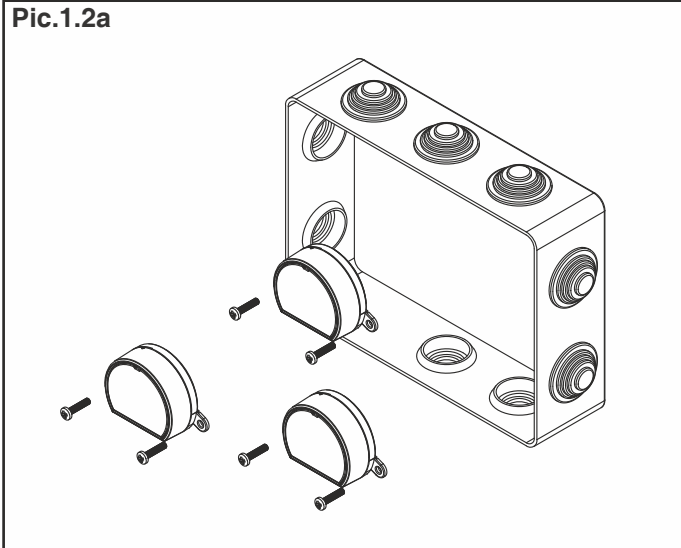

Pic.1.2b

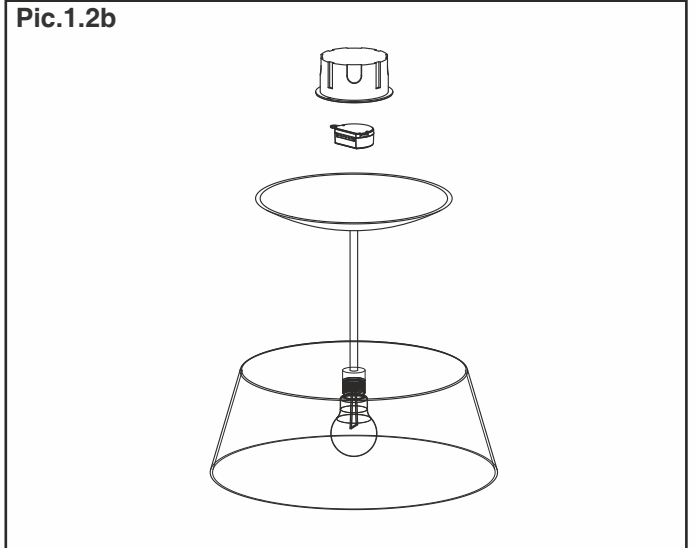

Pic.1.2c

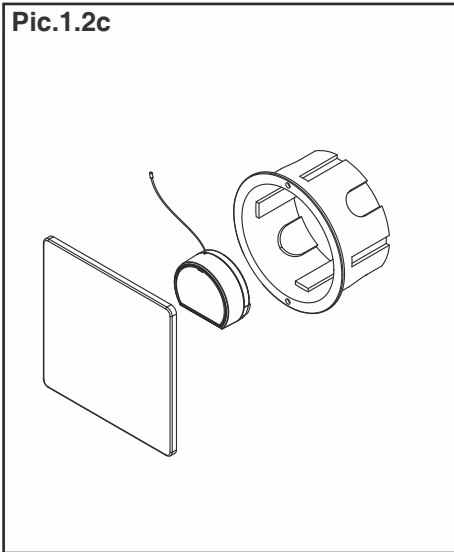

Pic.1.2d

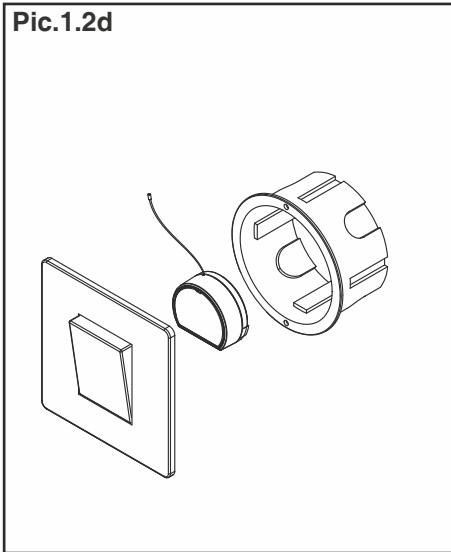

Pic.1.2e

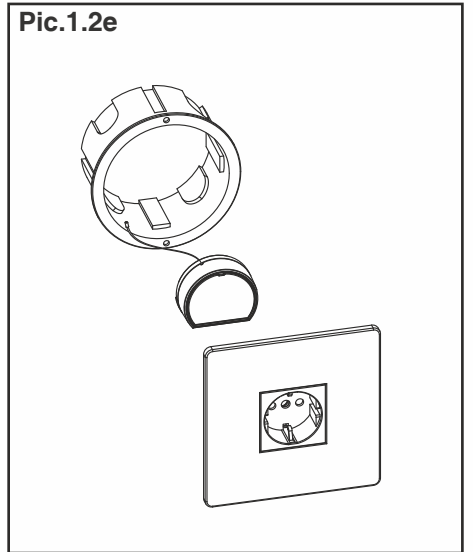

Pic.1.2f

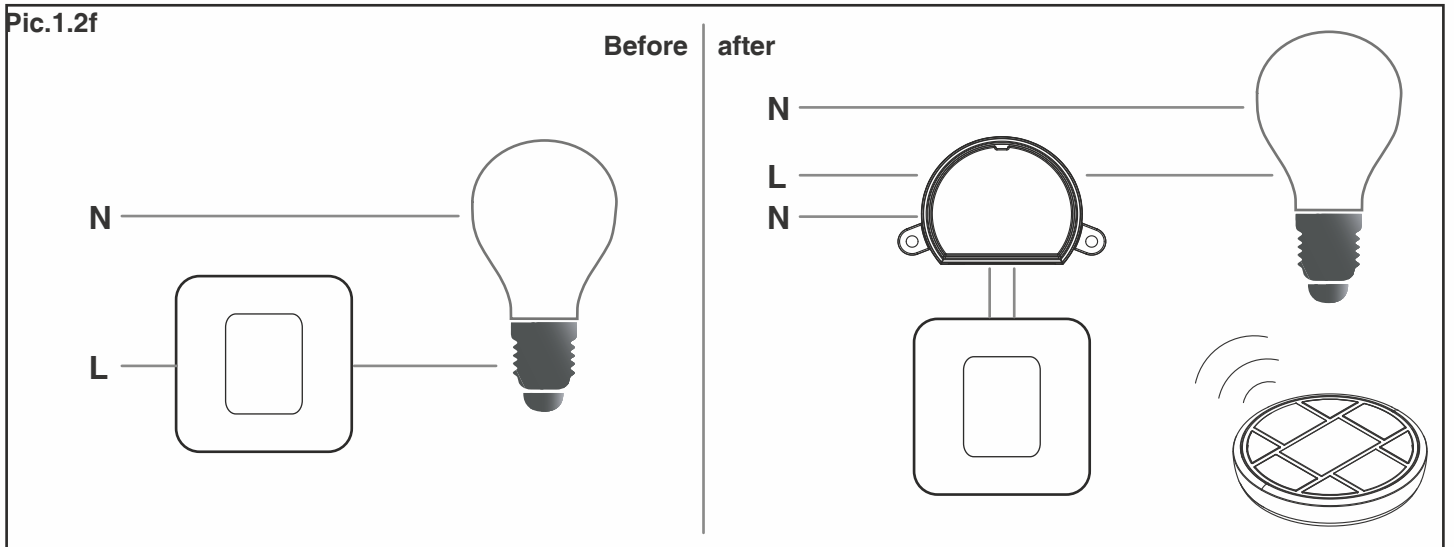

1.3 CONFIGURATION DEPENDING ON TYPE OF LAMP

The product is supplied with default settings that can be adapted to the different types of load.

However, depending on the type of connection (3/4 wires or 2 wires, see paragraph 2 and 4.6) and the manufacturing characteristics of the loads connected, some settings are recommended to optimise dimming and its range.

WARNING: If dimming is less than excellent, or there are problems with the power supply to the lamp, it is recommended that:

- if a two-wire connection has been used, a three or four-wire connection should be made (paragraph 2.1 or 2.2). Some types of loads are not suitable for this connection because of their manufacturing characteristics.

RESISTIVE LIGHTS, INDUCTIVE LOADS AND ELECTRONIC TRANSFORMERS:

To ensure that it operates well with all types of load, the product is supplied with a default adjustable minimum brightness.

To enjoy the full dimming range with these types of loads whose characteristics mean they usually even support low brightness values, just follow the "adjustable minimum brightness" procedure in paragraph 4.4.

LED LAMPS

The following procedure is not necessary but may optimise the operation of some LED lamps with manufacturing characteristics that mean they do not accept low brightness values during switch-on and dimming.

WITH SAVE FUNCTION NOT ON (see paragraph 4.5)

- Set the desired minimum intensity value accepted by the type of lamp with wired or radio commands
- Set this value as "adjustable minimum brightness", see paragraph 4.4

WITH SAVE FUNCTION ON (see paragraph 4.5)

WARNING: this set-up is not recommended with LED lamps that are not suitable if you want to be able to adjust low brightness values.

- Set the desired minimum brightness value accepted by the type of lamp with wired or radio commands
- Give an OFF command
- Give an ON command and check that the intensity supplied is enough to turn the light on
- If the light doesn't come on, adjust the dimmer at a higher level of intensity

WARNING: the light is off but the load is powered, use the "dimmer UP" command

- Try to turn the light on and off again
- Once the minimum intensity value that the lamp accepts is identified, set this value as "adjustable minimum brightness", see paragraph 4.4

2 ELECTRICAL CONNECTIONS

This control unit is set up for different types of connection that allow greater flexibility to adapt to different system configurations. These differ in terms of the number of wires required to power the control unit and/or load (see also paragraph 4.6).

2.1 THREE-WIRE CONNECTIONS

This is the standard connection. In fact with this type of wiring the control unit will always be powered, even with the load (e.g. bulb) disconnected.

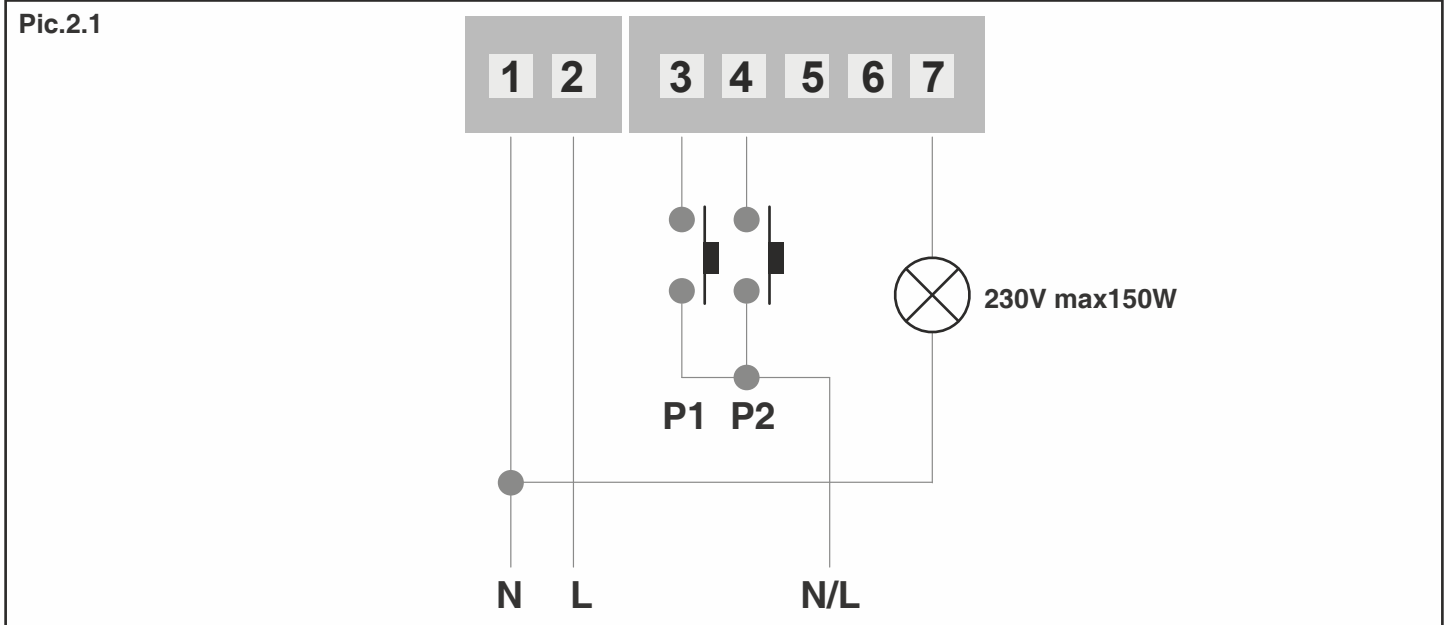

WARNING: multiple buttons or loads can be connected using parallel wiring.

2.2 FOUR-WIRE CONNECTIONS

As in the case of three-wire connections (paragraph 2.1), here again the control unit will always be powered. The neutral to the load will, however, be provided directly by the control unit itself.

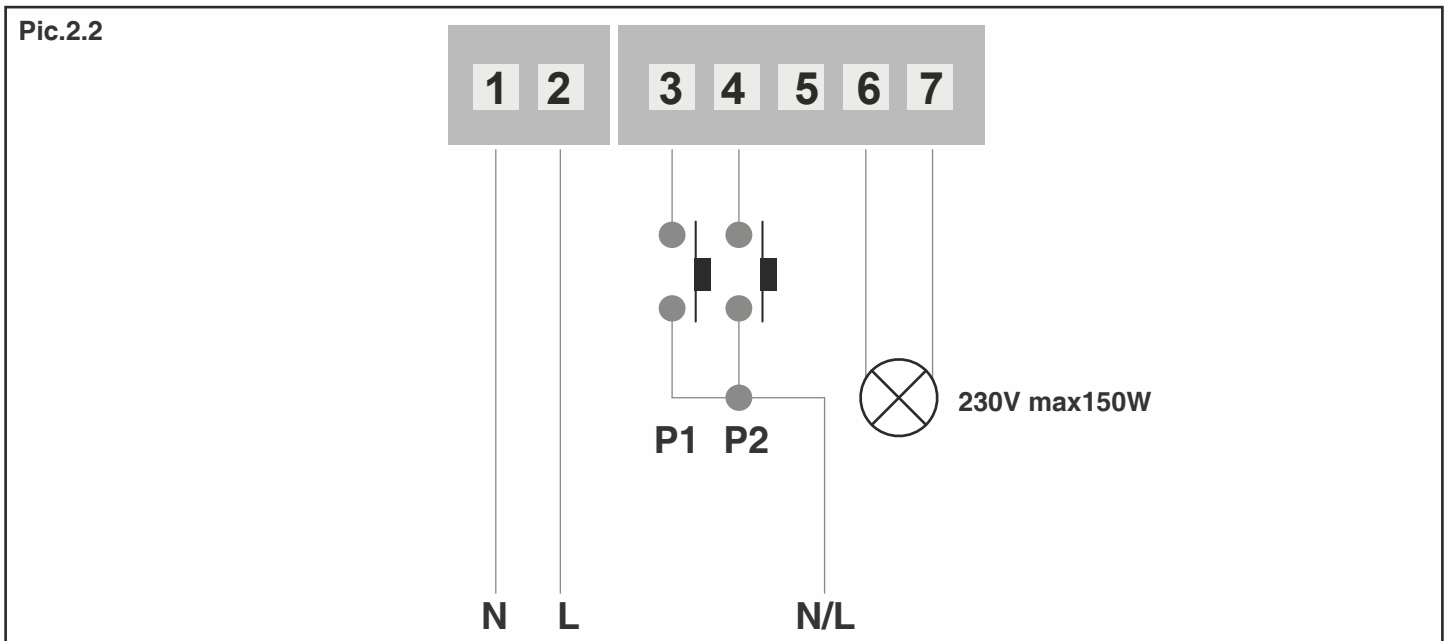

WARNING: multiple buttons or loads can be connected using parallel wiring.

3 USE OF THE CONTROL UNIT

3.1 USE VIA RADIO

To control the loads via radio you must have compatible transmitters and therefore must carry out the association procedure, see paragraph 5.

The transmitter's command modes depend on the model of transmitter used.

If the transmitter is of a generic type, its operation depends on the way it is programmed (see paragraph 5, table 5.2b).

If the transmitter is multifunctional, refer to the transmitter manual, to the paragraph entitled "commands sent by the transmitter", bearing in mind that it is a "dimmer" device.

3.2 USE VIA WIRE

WARNING: the connected devices must be buttons

The device is set up to accept commands via wire by button in terminals 3 and 4.

Should you want to control the load only via radio, it is not necessary to connect these devices for the control unit to work properly.

The behaviour of the different keys is shown in the following table.

	LOAD OFF	LOAD ON
INPUT P1: short pressure	Load on	Load off
INPUT P1: long pressure	Dimmer intensity up of load	Dimmer intensity up / Dimmer intensity down of load
INPUT P2: short pressure	No action	Soft Off 1 hr: gradually fades in an hour
INPUT P2: long pressure	No action	Soft Off 1 hr: gradually fades in an hour

WARNING: The behaviour of the inputs can be modified with the procedure shown in paragraph 4.1

4 CONTROL UNIT SETTINGS

4.1 CONFIGURATION OF BUTTONS VIA WIRE

Default: mode 1

This procedure is used to set up the operation of wired inputs "P1" and "P2".

PROCEDURE:

!: the following procedure must be done with turned-off load

STEP 1
Position DIPs 1, 2, 3 and 4 to OFF-ON-OFF-ON

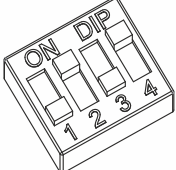

DIP 1, 2, 3, 4=
OFF ON OFF ON

STEP 2
Press the button on the receiver for a short time.
The LED comes on and stays on.

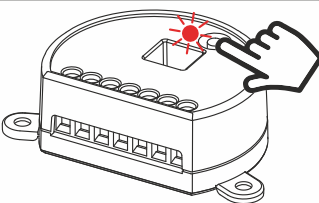

SHORT PRESSURE

STEP 3
Press the button on the receiver for a short time.

Count the number of flashes emitted by the LED:
6 flashes = MODE 1, see table 4.1a
3 flashes = MODE 2, see table 4.1b

NUMBER OF FLASH	TYPE OF INPUT
6	Mode 1
3	Mode 2

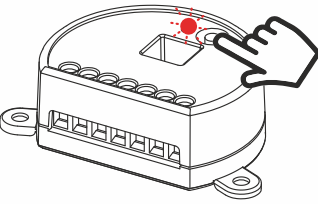

SHORT PRESSURE

STEP 4
To change the setting, repeat the procedure from point 1; the control unit will alternate between 3 and 6 flashes.

Table 4.1a - Behaviour of keys in mode1

	LOAD OFF	LOAD ON
INPUT P1: short pressure	On of load 1	Off of load 1
INPUT P1: long pressure	Dimmer Intensity Up of load 1	Dimmer intensity up / down of load 1
INPUT P2: short pressure	No action	Soft Off 1 hr: gradually fades in an hour
INPUT P2: long pressure	No action	Soft Off 1 hr: gradually fades in an hour

Table 4.1b - Behaviour of keys in mode2

	LOAD OFF	LOAD ON
INPUT P1: short pressure	On of load 1	Dimmer intensity Up of load 1
INPUT P1: long pressure	Dimmer intensity Up of load 1	Dimmer intensity Up of load 1
INPUT P2: short pressure	No action	Off load 1
INPUT P2: long pressure	No action	Dimmer intensity down of load 1

4.2 FADE SETTING: GRADUAL SWITCH ON

Default: 0.5 secs

This procedure means you can set the duration of the switch-on time.

PROCEDURE:

!: the following procedure must be done with turned-off load

STEP 1
Position DIPs 1, 2, 3 and 4 to ON-ON-OFF-ON.

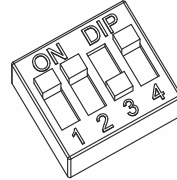

DIP 1, 2, 3, 4=
ON ON OFF ON

STEP 2
Press the button on the receiver for a short time.

The LED comes on and stays on.

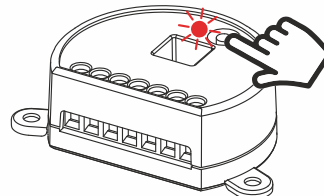

SHORT
PRESSURE

STEP 3
Press the button on the receiver for a short time
count the number of flashes emitted by the LED:

FLASHES	SWITCH-ON TIME
1 flash	immediate ON
2 flashes	ON ~ 0,5s
3 flashes	ON ~ 2s
4 flashes	ON ~ 4s
5 flashes	ON ~ 10s

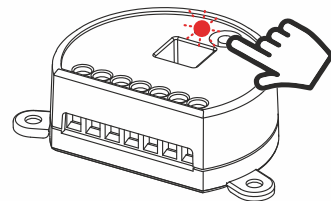

SHORT
PRESSURE

STEP 4
Press the button for a short time during the flash that corresponds to the function desired to end the count

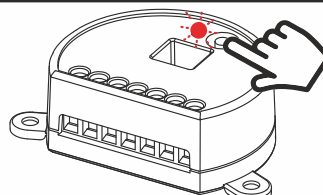

SHORT PRESSURE
DURING THE FLASH

4.3 FADE SETTING: GRADUAL SWITCH OFF

Default: 0.5 secs

This procedure means you can set the duration of the switch-off time.

PROCEDURE:

!: the following procedure must be done with turned-off load

STEP 1

Position DIPs 1, 2, 3 and 4 to ON-OFF-OFF-ON.

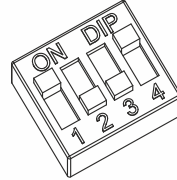

DIP 1, 2, 3, 4=
ON OFF OFF ON

STEP 2

Press the button on the receiver for a short time.

The LED comes on and stays on.

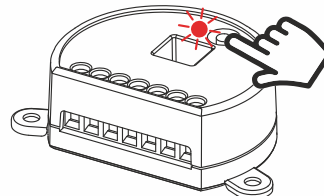

SHORT
PRESSURE

STEP 3

Press the button on the receiver for a short time count the number of flashes emitted by the LED:

FLASHES	SWITCH-OFF TIME
1 flash	immediate OFF
2 flashes	OFF ~ 0,5s
3 flashes	OFF ~ 2s
4 flashes	OFF ~ 4s
5 flashes	OFF ~ 10s

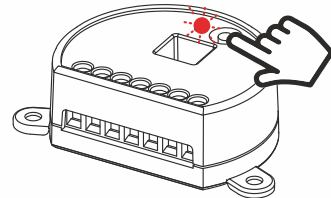

SHORT
PRESSURE

STEP 4

Press the button for a short time during the flash that corresponds to the function desired to end the count

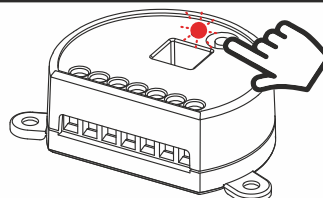

SHORT PRESSURE
DURING THE FLASH

4.4 SETTING ADJUSTABLE MINIMUM BRIGHTNESS

This procedure allows you to set the minimum level of brightness at which it is possible to adjust the load. The minimum level of brightness accepted at switch-on and dimming depends on the type of load connected.

PROCEDURE:

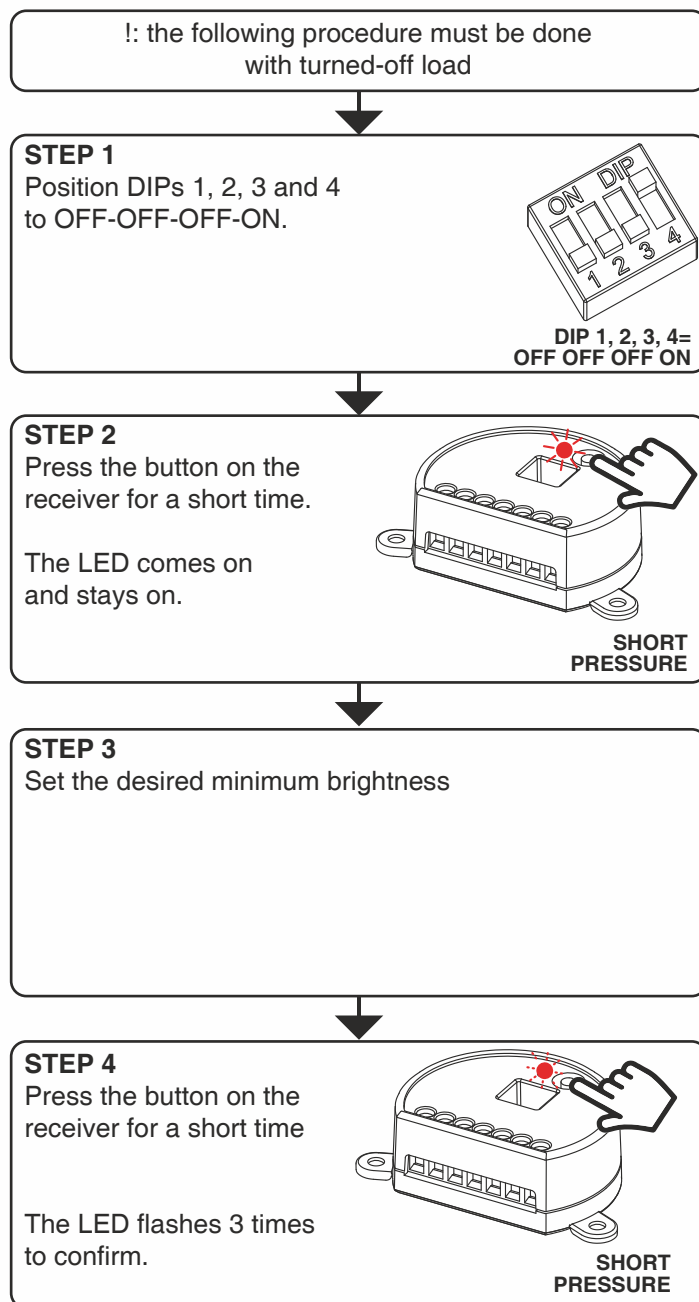

4.5 "SAVE" FUNCTION (BRIGHTNESS LEVEL AT SWITCH-ON)

Default: save not on

WARNING: with LED lamps that do not accept low brightness values (typical of LED bulbs), it is not advisable to use the save function to avoid the light being turned-off when there is insufficient intensity to turn on the actual light.

PROCEDURE:

!: the following procedure must be done with turned-off load

STEP 1

Position DIPs 1, 2, 3 and 4 to OFF-ON-OFF-OFF.

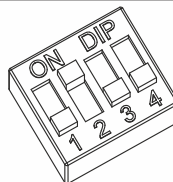

DIP 1, 2, 3, 4=
OFF ON OFF OFF.

STEP 2

Press the button on the receiver for a short time.

The LED comes on and stays on.

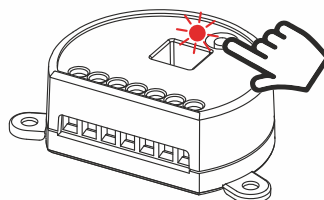

SHORT
PRESSURE

STEP 3

Press the button on the receiver for a short time

Count the number of flashes emitted by the LED:

3 flashes= Last value set

6 flashes= Maximum brightness

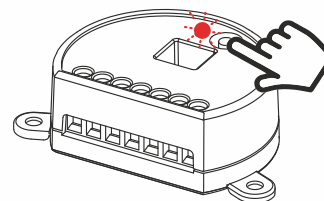

SHORT
PRESSURE

NUMBER OF FLASH	INTENSITY AT SWITCH-ON
3	Last value set
6	Maximum brightness

STEP 4

To change the setting, repeat the procedure from point 1; the control unit will alternate between 3 and 6 flashes.

4.6 TWO-WIRE CONNECTIONS

Default: three-wire connections (see paragraph 2)

This procedure is used to set up the type of connection of the load. This kind of set up allow the device to adapt to the power supply in order to correct manage of the load.

PROCEDURE:

!: the following procedure must be done with turned-off load

STEP 1

Position DIPs 1, 2, 3 and 4 to OFF-OFF-OFF-OFF

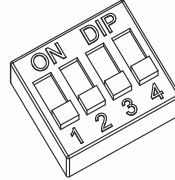

DIP 1, 2, 3, 4=
OFF OFF OFF OFF

STEP 2

Press the button on the receiver for a short time.

The LED comes on and stays on.

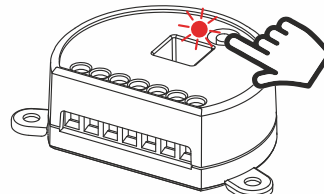

SHORT
PRESSURE

STEP 3

Press the button on the receiver for a short time.

Count the number of flashes emitted by the LED:
3 flashes= three-wire connections. (see paragraph 2)
6 flashes= two-wire connections (see picture 4.6)

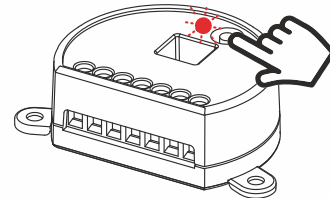

SHORT
PRESSURE

NUMBER OF FLASHES	TYPE OF CONNECTION
3	three-wire connections (see paragraph 2)
6	two-wire connections (see picture 4.6)

STEP 4

to change the setting, repeat the procedure from point 1;
the control unit will alternate between 3 or 6 flashes.

CONNECTION DIAGRAM

This connection is provided in existing systems to make wiring easier for the installer. Some types of loads are not suitable for this connection because of their manufacturing characteristics. If dimming is less than excellent, or there are problems with the power supply to the lamp, it is advisable to use a three or four-wire connection (paragraph 2.1 or 2.2).

WARNING: with this wiring it is necessary to connect the load (e.g. lamp) to be able to power the control unit.
WARNING: with this wiring the minimum power of the load that can be connected is 20 W

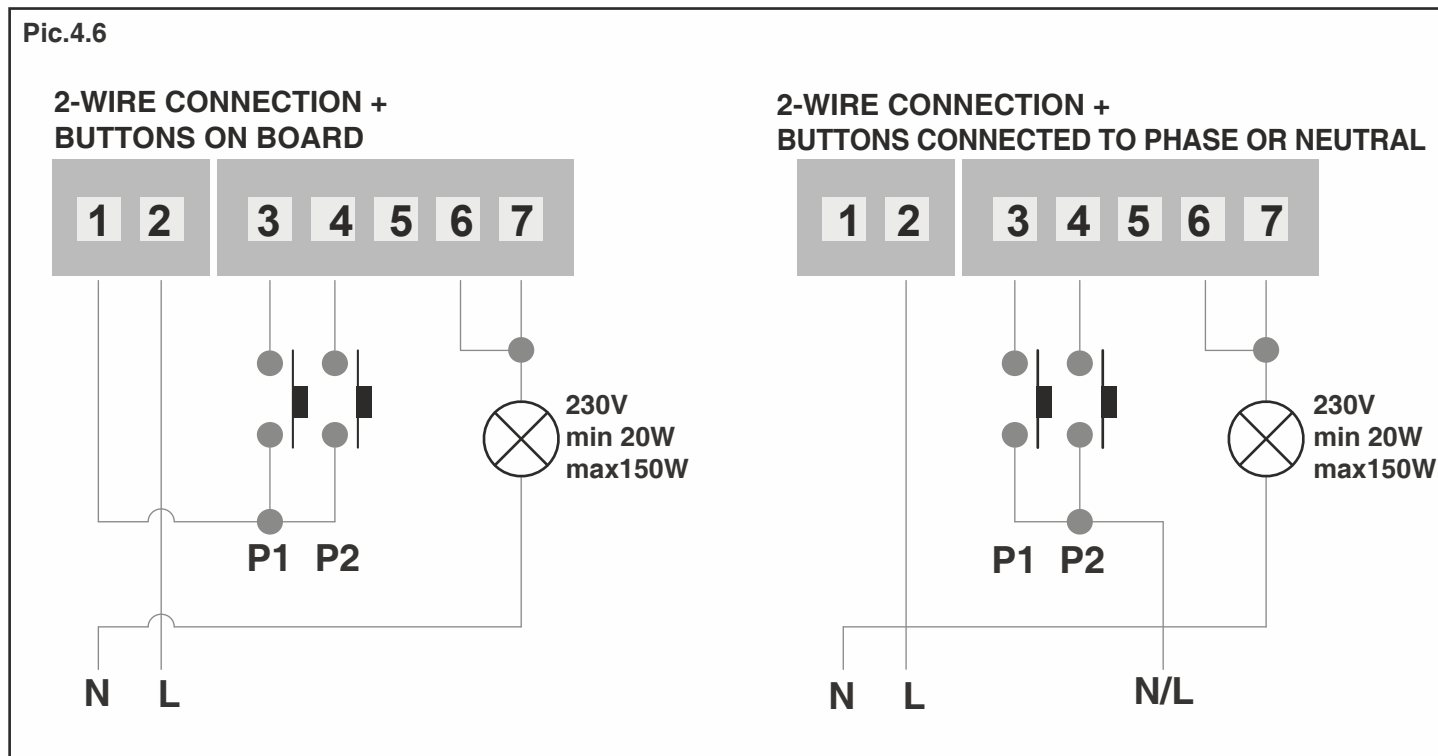

WARNING: multiple buttons or loads can be connected using parallel wiring.

5 - RADIO PROGRAMMING

This procedure lets you programme compatible multifunctional or generic transmitters.

WHICH REMOTE CONTROL DO YOU WANT TO ASSOCIATE WITH THE CONTROL UNIT?

MULTIFUNCTIONAL TRANSMITTERS

CODES:

HB70-SLCT, HB70-SPCT,
 HB80-1C, HB80-1DIM, HB80-2L, HB80-30D, HB80-30RGBW, HB80-4C, HB80-4DIM, HB80-4L,
 HB90-6LT,
 ROUND-1SP,
 SENSА-M, SENSА-P, SENSА-R35M, SENSА-R35P, SENSА-R35T, SENSА-T,
 TOUCH-1, TOUCH-1CCT, TOUCH-1DIM, TOUCH-1SP, TOUCH-1L, TOUCH-1RGBW, TOUCH-3C, TOUCH-4DIM, TOUCH-CFU

With multifunctional transmitters the transmitter control modes depend on the model used. Refer to the transmitter manual, to the paragraph entitled "commands sent by the transmitter", bearing in mind that it is an "dimmer" device.

GENERIC TRANSMITTERS (WIRELESS BUS)









CODES:

HB80-6G,
 MCU-TX4,
 TOUCH-1G, TOUCH-2G, TOUCH-4G, TOUCH-LOCK4, TOUCH-TX2,
 ROUND-1G

With generic transmitters, the transmitter's control modes depend on the function associated with the key during the association procedure.

The available function for the key are:

TABLE 5.1 - KEY FUNCTIONS OF THE GENERIC TRANSMITTER

POSITION OF DIP IN "STEP 1b" OF THE PROCEDURE	KEY FUNCTION	POSITION OF DIP IN "STEP 1b" OF THE PROCEDURE	KEY FUNCTION
 DIP: OFF ON ON ON	DIMMER UP	 DIP: ON OFF ON OFF	ON
 DIP: ON OFF ON ON	DIMMER DOWN	 DIP: OFF OFF ON OFF	Short pressure= ON Long pressure= DIMMER UP
 DIP: OFF OFF ON ON	ON/OFF	 DIP: ON ON OFF OFF	Short pressure= OFF Long pressure= DIMMER DOWN
 DIP: ON ON ON OFF	Short pressure= ON / OFF Long pressure= DIMMER UP / DIMMER DOWN	 DIP: ON OFF OFF OFF	Soft Off 1h: fade off in 1h.
 DIP: OFF ON ON OFF	OFF		

PROCEDURE

WHICH TRANSMITTER DO YOU WANT TO PROGRAMME?

MULTIFUNCTION TRANSMITTER
(see models and codes on previous page)

GENERIC TRANSMITTER
(see models and codes on previous page)

STEP 1a
Position DIPs 1, 2, 3 and 4 to ON-ON-ON-ON

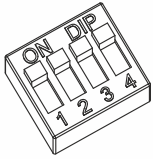

DIP 1, 2, 3 e 4= ON ON ON ON

STEP 1b
Positions DIPs 1, 2, 3 and 4 according to the function you want to associate with the remote control key.
See table 5.1 on the previous page.

STEP 2
Press the button on the receiver for a short time.
The LED comes on and stays on.

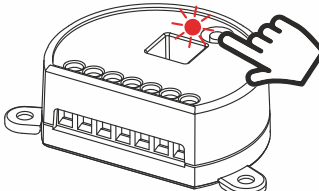

SHORT PRESSURE

STEP 3
Make a transmission with the transmitter to be saved (see transmitter manual, paragraph entitled "transmitter programming").
The LED on the receiver flashes 3 times to signal that it has been received.

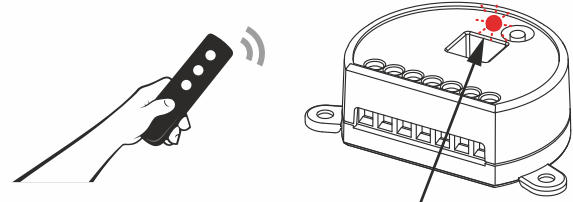

MAKE A TRANSMISSION WITH THE TRANSMITTER **THE LED FLASHES 3 TIMES**

STEP 4
The control unit listens for 30 seconds in case you want to add other transmitters.
To immediately exit the procedure give a short pressure on the button on the receiver.
The LED turns off

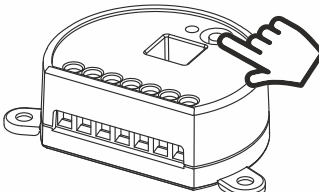

SHORT PRESSURE

6 - DELETION OF TRANSMITTERS

These procedures let you delete from the memory transmitters that have already been programmed.

6.1 DELETION OF SINGLE TRANSMITTER:

STEP 1

Hold the receiver button down for 8 seconds.

The LED begins to flash

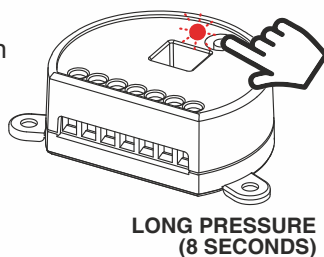

STEP 2

Make a transmission with the transmitter that you want to delete.

The LED flashes quickly and turns off.



MAKE A TRANSMISSION
WITH THE TRANSMITTER

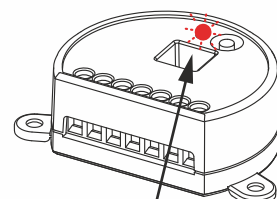

LED FLASHES QUICKLY

6.2 DELETION OF ALL THE SAVED TRANSMITTERS

STEP 1

Hold the receiver button down for 8 seconds.

The LED begins to flash.

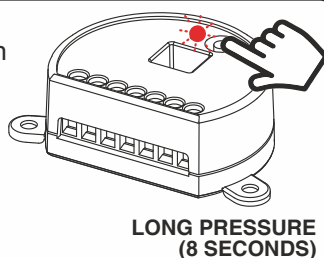

STEP 2

Press the button on the receiver for a short time.

The LED starts flashing quickly and turns off

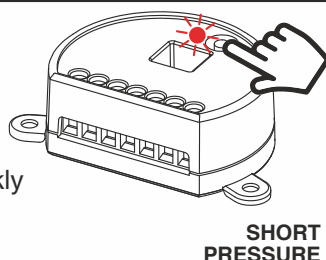



LEF•LIGHTING S.R.L.
Sede Legale: Via R. Morandi 9/11 -
50019 Sesto Fiorentino (FI)
Sede Operativa: Via Sandro
Pertini, 71/73 - 50019 Sesto
Fiorentino (FI)
Tel: +39 055 4217727
Fax: +39 055 4217719
C.F./P.IVA 06741590480